

# Effect of geometrical artifacts on signal from INO-ICAL RPC

Abhik Jash

INO collaboration  
Saha Institute of Nuclear Physics  
Kolkata

December 9, 2014

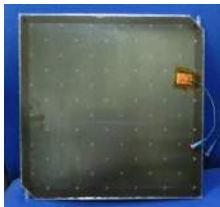

# Outline

- 1 Motivation
- 2 Investigation of field
- 3 Signal calculation
  - Weighting field
  - RPC signal
- 4 Experimental activity
- 5 Future plans

- 1 Motivation
- 2 Investigation of field
- 3 Signal calculation
  - Weighting field
  - RPC signal
- 4 Experimental activity
- 5 Future plans

# Motivation

- Resistive Plate Chamber (RPC) is a robust and affordable gaseous detector having simple signal pick-up and read-out system, which is extensively used in many HEP and astro-particle experiments.

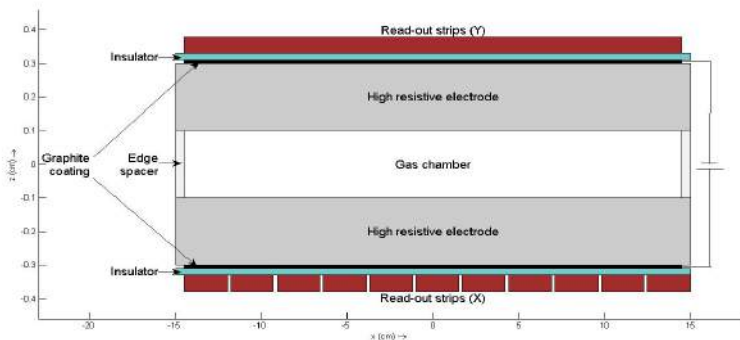

Schematic diagram of an RPC

## RPC : characteristics

- Built from simple and common materials, so can be fabricated to have large coverage area at low cost.
- They are easy to stack one above the other to have 3D spatial information.
- Very good time resolution (few ns) and detection efficiency ( $> 90\%$ ).
- They have long term stability.
- RPC is the active detector element for INO-ICAL [1] detector, which will study atmospheric neutrinos to make precise measurement of the neutrino oscillation parameters  $|\Delta m_{31}^2|$ ,  $\sin^2 2\theta_{23}$  and also will shed light on neutrino mass hierarchy (sign of  $\delta_{32}$ ).

## INO Iron CALorimeter (ICAL)

- Three modules each of lateral size  $16.2\text{m} \times 16\text{m}$  and height  $14.5\text{m}$  weighing about  $50\text{ kTon}$  in total.
- Each module contains 150 layers of RPCs ( $1.95\text{m} \times 1.91\text{m}$ ) interleaved with magnetized ( $\sim 1.3\text{ T}$ ) iron plates.
- The energy and direction of the muons produced by the interaction of neutrinos with the iron nuclei will be found out from the hit and timing information from RPCs.

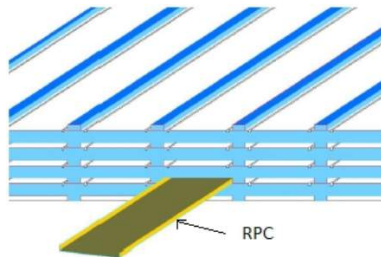

RPC for INO-ICAL detector

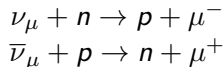

# Motivation (cont.)

- We are trying to understand the detailed physics behind the operation of RPC which will help in optimizing the detector parameters and interpreting the result.
- At present, aim is to find out effect of geometrical artifacts, gas flow scheme etc on RPC response.
- Early r&d works on the INO-ICAL prototype have shown reduced response from RPC near edges, corners and button spacers than a regular point.
- Physical field, gas flow scheme may be the possible reasons.

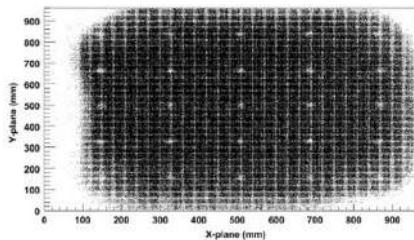

Dead space near Edge, corner and spacers (fig. from [2])

- Detail field map within RPC has been generated.
- Presence of uniform gas mixture all over the gas chamber has been assumed.

# Outline

- 1 Motivation
- 2 Investigation of field
- 3 Signal calculation
  - Weighting field
  - RPC signal
- 4 Experimental activity
- 5 Future plans



# Field map within RPC

- Simulation of electric field for a  $30\text{cm} \times 30\text{cm}$  RPC.
- Field solvers used :  
**COMSOL** [3] v4.4 : Based on Finite Element Method (FEM).  
**neBEM** [4] v1.8.16 : Based on Boundary Element Method (BEM), interfaced with Garfield [5].
- Model specifications :  
RPC plates : Bakelite ( $\epsilon = 6.4$ ).  
Edge spacers : Mica ( $\epsilon = 5.4$ ).  
Gas : air ( $\epsilon = 1.0013$ ).  
Conductive coating : Graphite.  
H.V. applied :  $\pm 5$  kV.

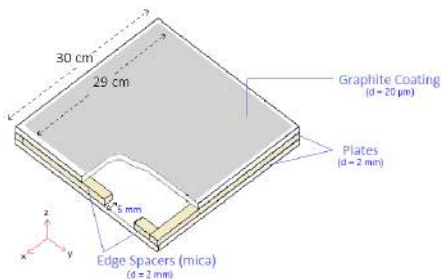

RPC model used in simulation studies

# Field map within RPC (cont.)

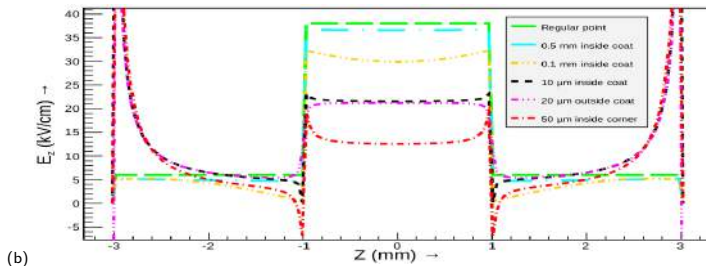
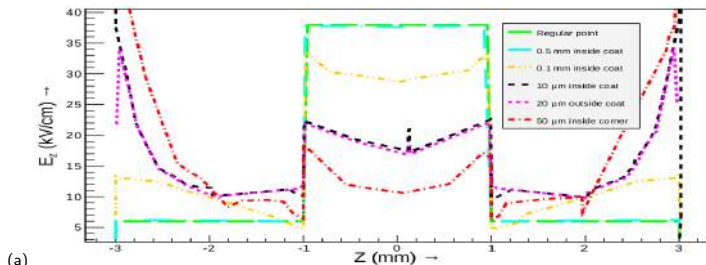

Effect of edge and corner on RPC field, as computed by (a) COMSOL, (b) neBEM.

# Outline

- 1 Motivation
- 2 Investigation of field
- 3 Signal calculation**
  - Weighting field
  - RPC signal
- 4 Experimental activity
- 5 Future plans

## Importance :

Signal induced on RPC pickup strip due to movement of charge in gas chamber is given by **Shockley-Ramo theorem** -

$$i(t) = q \vec{v}(t) \cdot \vec{W}(\vec{x}(t))$$

$\vec{v}(t)$  → Instantaneous velocity of the charge  $q$ .

$\vec{W}(\vec{x}(t))$  → Weighting field associated with the electrode under study. It is the field produced when the electrode under study is at unit potential and all other electrodes are at ground potential.

- This will provide an idea about dependence of RPC response on pickup strip position.
- Calculated both Numerically and Analytically.

# Weighting field : Calculation (Numerical Method)

- Calculated for all the pickup strips of RPC.
- Both COMSOL and neBEM is used.

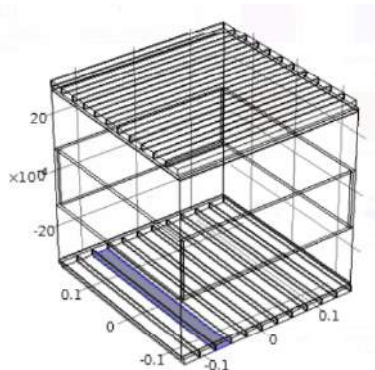

Calculation of weighting field for strip 2

- Graphite coat considered as dielectric ( $\epsilon = 12.0$ ).
- Strip of interest is at value 1.
- All other strips are at value 0.

# Weighting field : Calculation (Analytic Method)

- Calculated using MATLAB based on the paper: Th Heubrandtner, B Schnizer, C Lippmann, W Riegler - Nucl. Instr. and Meth., 489 (2002), p. 439.

Weighting field,

$$E_z(x, z) = V_1 \epsilon_1 \frac{2}{\pi} \times \int_0^{\infty} dk \cos(kx) \sin\left(k \frac{w}{2}\right) F_2(k, z)$$

with,  $F_2(k, z) = -\frac{2}{D(k)} [(\epsilon_2 + \epsilon_3)(e^{-k(q+z)} + e^{-k(2p+q-z)}) - (\epsilon_2 - \epsilon_3)(e^{-k(q+2g-z)} + e^{-k(2p+q-2g+z)})]$

and

$$D(k) = (\epsilon_1 + \epsilon_2)(\epsilon_2 + \epsilon_3)(1 - e^{-2k(p+q)}) - (\epsilon_1 - \epsilon_2)(\epsilon_2 + \epsilon_3)(e^{-2kp} - e^{-2kq}) - (\epsilon_1 + \epsilon_2)(\epsilon_2 - \epsilon_3)(e^{-2k(p-g)} - e^{-2k(q+g)}) + (\epsilon_1 - \epsilon_2)(\epsilon_2 \epsilon_3)(e^{-2kg} - e^{-2k(p+q-g)})$$

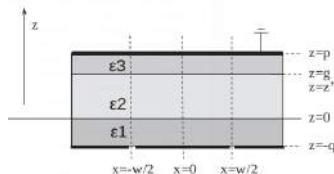

Geometry to calculate Weighting field for RPC

- Calculated for 3-layer geometry, whereas RPC is a 7-layer geometry.
- Electrodes have infinite dimension along y-direction.
- There is no gap between the strips.

# Weighting field : Result

## Numerical method

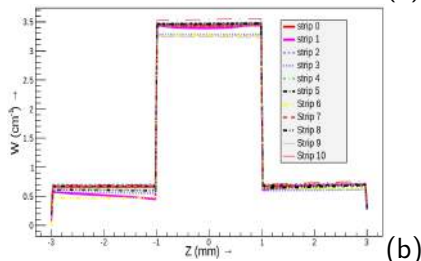
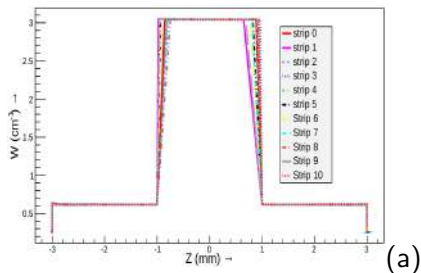

## Analytic method

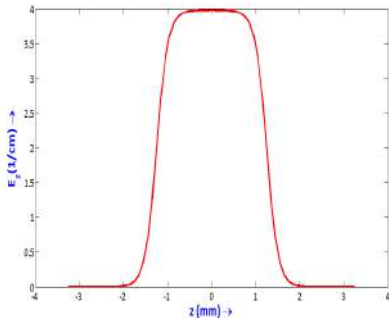

Weighting field from MATLAB

Weighting field using (a) COMSOL, (b) neBEM

- Electric field map within the chamber : [neBEM/COMSOL](#).
- Calculation of gas properties (Townsend coefficient, attachment coefficient, longitudinal and transverse drift velocity of electrons) : [MagBoltz](#) → Solves the Boltzman transport equations for electrons in arbitrary gas mixtures.
- Interaction of relativistic charged particle with the gas medium and their energy loss : [HEED/Geant4](#).
- [Garfield](#) framework has been used to calculate the signal induced on the RPC pick-up strip.



# Signal calculation (cont.)

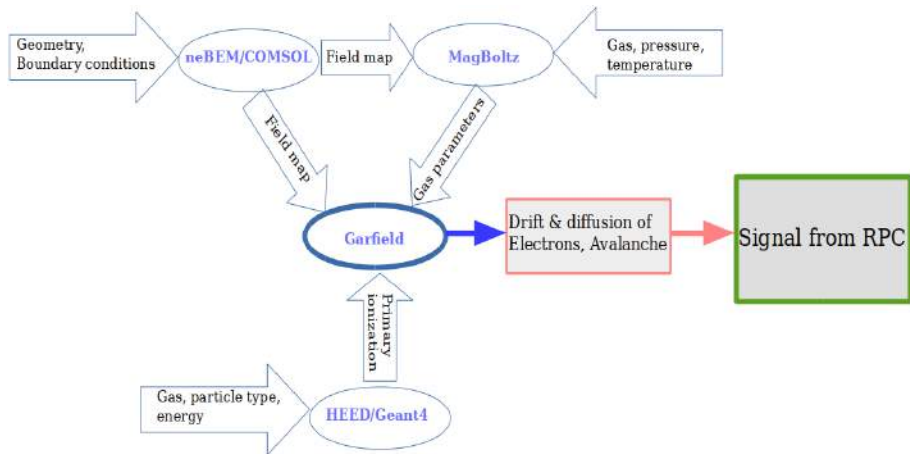

Garfield framework to simulate RPC signal

# Signal calculation (cont.)

- Gas mixture used  $\rightarrow$  Freon (134A) : Isobutane = 95 : 5 (in %).
- Applied voltage for simulation:  $\pm 6$  kV ( $E_z = 46$  kV/cm).

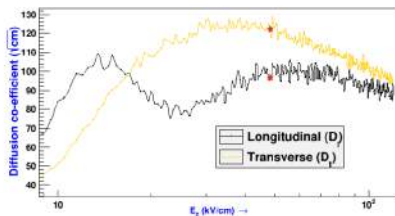
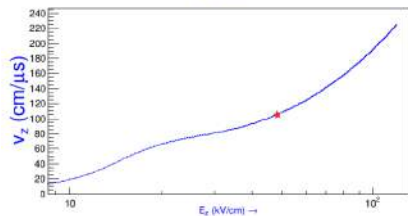
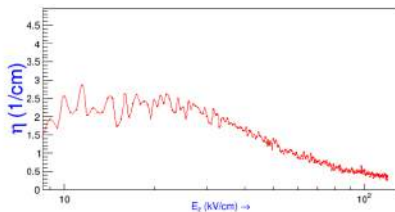
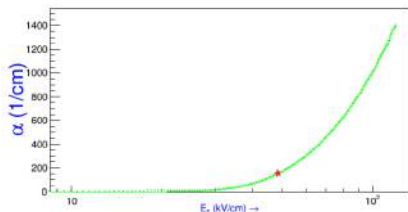

Variation of Townsend coefficient ( $\alpha$ ), Attachment coefficient ( $\eta$ ), Electron drift velocity ( $V_z$ ) and Diffusion coefficients ( $D_l$  and  $D_t$ ) with applied field ( $E_z$ ) from MagBoltz.

# Signal calculation (cont.)

- Passage of 1 GeV muon through RPC gas chamber, 5 ° inclination with z axis.
- Pick-up plane is a plate (no strip) for simplicity.

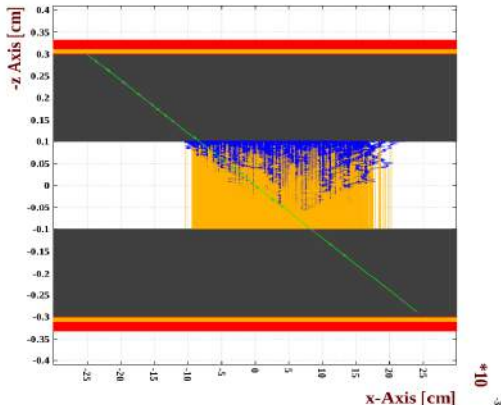

Avalanche produced due to drift of electrons and ions within RPC gas chamber

## Signal calculation (cont.)

- Signal from lower pickup panel (towards the side of Anode).
- Appearance of long tail for slow ion movement.

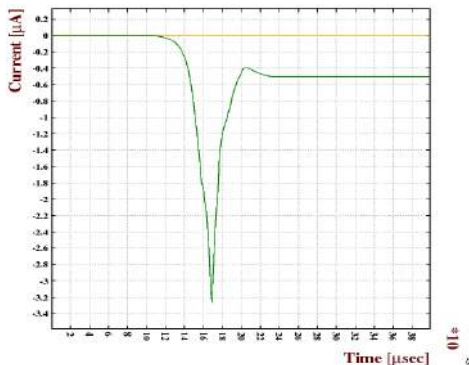

Typical RPC signal from simulation.

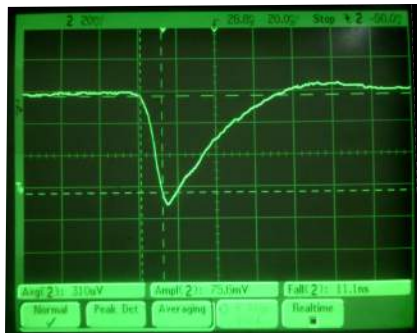

RPC signal as seen on Oscilloscope.

- Rise time of pulse  $\sim 11$  ns.
- Rise time from simulation = 7 ns.

# Outline

- 1 Motivation
- 2 Investigation of field
- 3 Signal calculation
  - Weighting field
  - RPC signal
- 4 Experimental activity
- 5 Future plans

- Two Bakelite RPCs of dimension  $30\text{ cm} \times 30\text{ cm}$  have been fabricated, one (B1+) with silicon oil coating on its inner surface and another (B2-) without the coating.
- B1+ is tested and characterized.
- Measurements from both will help comparing the effect of surface smoothness on RPC characteristics.
- Measurements at different positions of an RPC will help in understanding the effect of geometrical artifacts on RPC characteristics.

# Experimental activity (cont.)

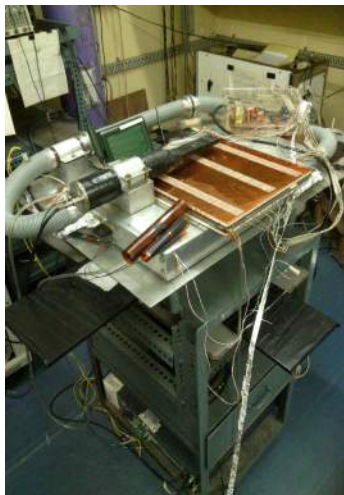

Experimental setup

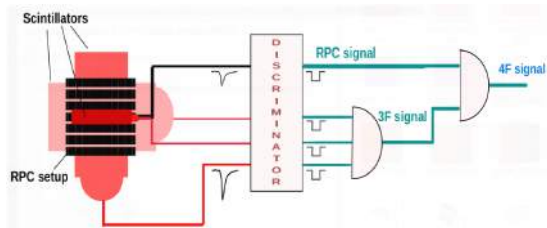

circuit diagram for efficiency and noise rate measurement

- Threshold set in discriminator-  
RPC strip : 10 mV  
Finger scintillator : 15 mV  
Other two scintillators : 24 mV

# Experimental activity (cont.)

- Efficiency (%) =  $\frac{4F}{3F} \times 100$   
3F = AND of signals from 3 scintillators.  
4F = AND of 3F and RPC strip signal.
- Noise rate( $\text{Hz}/\text{cm}^2$ ) =  $\frac{\text{singles count}}{\text{strip area} \times \text{counting time}}$   
singles count = any signal from RPC strip which crosses threshold.

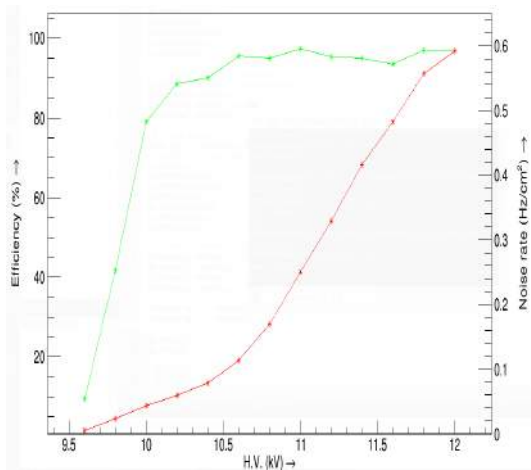

Variation of efficiency and noise rate of RPC B1+ with H.V.



# Experimental activity (cont.)

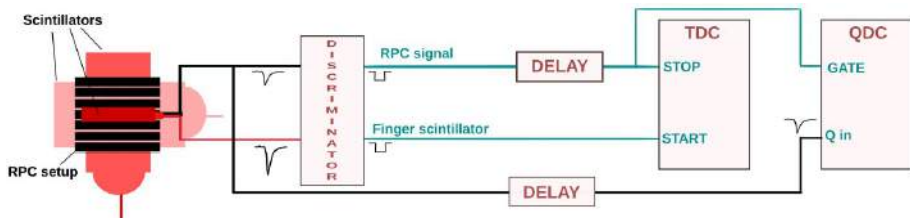

Schematic diagram for TDC and QDC measurement

- TDC START : finger scintillator.
- TDC STOP : RPC strip.
- QDC GATE : from RPC strip.
- Data acquisition using LAMPS.
- Operating voltage :  $\pm 5.8$  kV.
- Typical signal amplitude on CRO : 100 - 150 mV
- Discriminator threshold for RPC strip = 120 mV.

# Experimental activity (cont.)

## TDC measurements

- Variation of room temperature : 21.5 - 23 °C, humidity : 42 - 58 %.
- Value of time resolution from Gaussian fit.

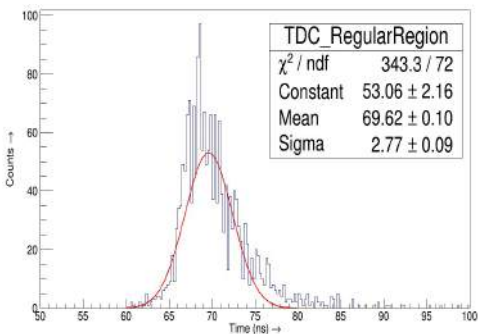

At a regular region

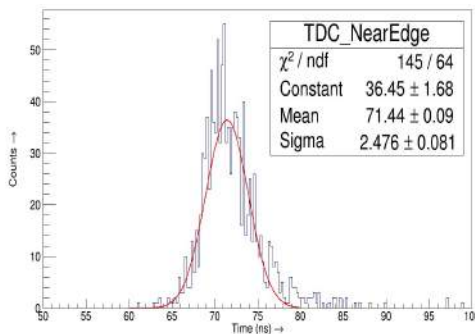

At a region near edge

- Time resolution = 2.77 ns.

- Time resolution = 2.48 ns.

## QDC measurements

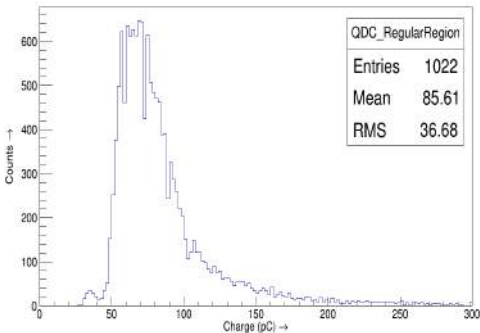

At a regular region

- Distribution peak at 69 pC.

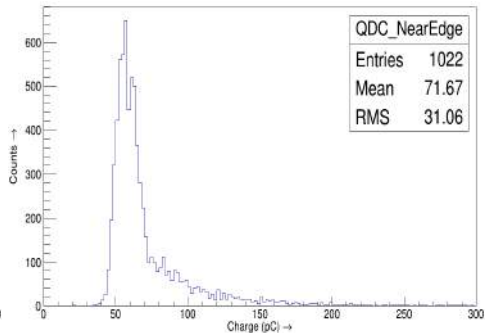

At a region near edge

- Distribution peak at 57 pC.

# Outline

- 1 Motivation
- 2 Investigation of field
- 3 Signal calculation
  - Weighting field
  - RPC signal
- 4 Experimental activity
- 5 Future plans

# Future plans

- Fine tuning the simulation parameters to approach more realistic condition and verifying it with experimental data.
- Find out change in RPC response according to strip position and surface smoothness of electrodes, experimentally and numerically.
- Fabricate a miniature pick-up strip to measure position-dependent charge and timing properties of an RPC.
- Simulate the gas flow within RPC gas chamber and find out dead regions and the effect of gas flow scheme on RPC response.

# References

- [1] India-based Neutrino Observatory.  
*<http://www.ino.tifr.res.in/ino/>*
- [2] M. Bhuyan et al.  
Cosmic ray test of INO RPC stack.  
*Nucl. Instrum. Meth. A* 661 (2012) S68.
- [3] COMSOL: a multiphysics simulation tool.  
*<http://www.comsol.co.in>*
- [4] N. Majumdar and S. Mukhopadhyay.  
Simulation of 3D electrostatic configuration in gaseous detectors.  
2007 *JINST* 2 P09006.
- [5] Garfield - Rob Veenhof.  
*<http://garfield.web.cern.ch/garfield>*

# Acknowledgment

- Dr. **Nayana Majumdar** (SINP), Dr. **Supratik Mukhopadhyay** (SINP), Dr. **Subhasis Chattopadhyay** (VECC) for their guidance and supervision over my work.
- Dr. **Satyajit Saha** for his help and suggestions regarding experimental activities.
- Ms. **Purba Bhattacharya** (SINP) for helping me with Garfield work.
- Ms. **Meghna K. K.** (IMSc) for her help during experimental arrangements.
- Mr. **Ganesh Das** (VECC) for helping me fabricating the first Bakelite RPC.
- Mr. **Deb Sankar Bhattacharya** (SINP), Ms. **Sananda Das** for all the helpful discussions.
- **INO collaboration** for financial support and suggestions at different stages of my work.

# Acknowledgment

- Dr. **Nayana Majumdar** (SINP), Dr. **Supratik Mukhopadhyay** (SINP), Dr. **Subhasis Chattopadhyay** (VECC) for their guidance and supervision over my work.
- Dr. **Satyajit Saha** for his help and suggestions regarding experimental activities.
- Ms. **Purba Bhattacharya** (SINP) for helping me with Garfield work.
- Ms. **Meghna K. K** **Thank You** 1g experimental arrangements.
- Mr. **Ganesh Das** (VECC) for helping me fabricating the first Bakelite RPC.
- Mr. **Deb Sankar Bhattacharya** (SINP), Ms. **Sananda Das** for all the helpful discussions.
- **INO collaboration** for financial support and suggestions at different stages of my work.