

DIRECT NEUTRINO MASS MEASUREMENTS

V M DATAR

Nuclear Physics Division Bhabha Atomic Research Centre Trombay, Mumbai 400 085 (India)

(Received 30 January 2003; Accepted 30 June 2003)

The direct neutrino mass measurements for neutrinos of the three flavours are reviewed.

Key Words: Beta Spectrum from Tritium; Troitsk Experiment; Mainz Experiment; Limits from Supernova Neutrinos; Muon and Tau Neutrino Masses

1 Introduction

The mass of the neutrino is a quantity of fundamental interest both from the viewpoint of particle physics as well as astrophysics. Although the mass of the neutrino of any flavour could be different from that of the corresponding antineutrino, the CPT theorem requires that they be the same. Recent experiments from Super Kamiokande Collaboration (SK) on atmospheric neutrinos have confirmed the anomaly seen earlier in the ratio of N_μ/N_e (observed) and N_μ/N_e (calculated) as a function of azimuthal angle, where N refers to the number of neutrinos and antineutrinos of a particular flavour. The most likely explanation is in terms of neutrino oscillations. The results can be interpreted in terms of an allowed region of Δm^2 (mass-squared difference) and $\sin^2 2\theta$, where θ is the mixing angle. Further, the experiments detecting solar neutrinos found a substantial reduction in the flux compared to that expected from the standard solar model and one of the explanations was in terms of neutrino oscillations. Clinching evidence for oscillation has now been found by the Sudbury group using the SNO heavy water detector by measuring the total active neutrino flux through the neutral current interaction¹. Another crucial result is from the Kamland collaboration which has found the first evidence² of a depletion of electron antineutrinos from nuclear power reactors. All these experiments which imply neutrino oscillations

give the difference of mass squares. The absolute mass scale however can only be determined by experiments which directly address the mass of the neutrino.

None of the direct measurements have so far yielded a non-zero value for the neutrino mass but only upper limit on their masses. Of the three flavours of neutrinos, ν_e , ν_μ and ν_τ , the third neutrino is the most difficult to produce and hence the most poorly measured. The first type is the most commonly produced and has the tightest upper bound on its mass. In the following we shall try to present the current status of direct mass measurements. The search for neutrinoless double beta decay and its impact on a possible non-zero Majorana neutrino mass is not discussed here and will be discussed separately in this volume. Also not discussed here are searches for possible heavy neutrino mixing in beta decay of nuclei³.

A neutrino produced in the weak decay of a hadron is in a lepton number eigenstate $l = e, \mu, \tau$. This is, in general, not a mass eigenstate and can be written in terms of a superposition of the various mass eigenstates i with the appropriate mixing amplitudes U_{li} . The spectrum of the electron in beta decay is given by

$$N(E, Z) = AF(E, Z) p E \sum_j W_j (Q_j - E) \times \sum_i U_{ei}^2 \sqrt{(Q_j - E)^2 - m_{\nu_i}^2 c^4}, \dots (1)$$

where N is the number of electrons of energy E , momentum p , from the decay of a nucleus with atomic number Z ; F is the appropriate Fermi function, W_j is the probability of decay to final state j with an end point energy of Q_j and m_{ν_i} is the i^{th} neutrino mass.^a

^a In principle one cannot assign definite masses to neutrino flavours but only to the mass eigenstates which mix to give the flavour states as is clear from eq.1. However, when one refers to the limit on the neutrino mass often a particular flavour, rather loosely, is mentioned.

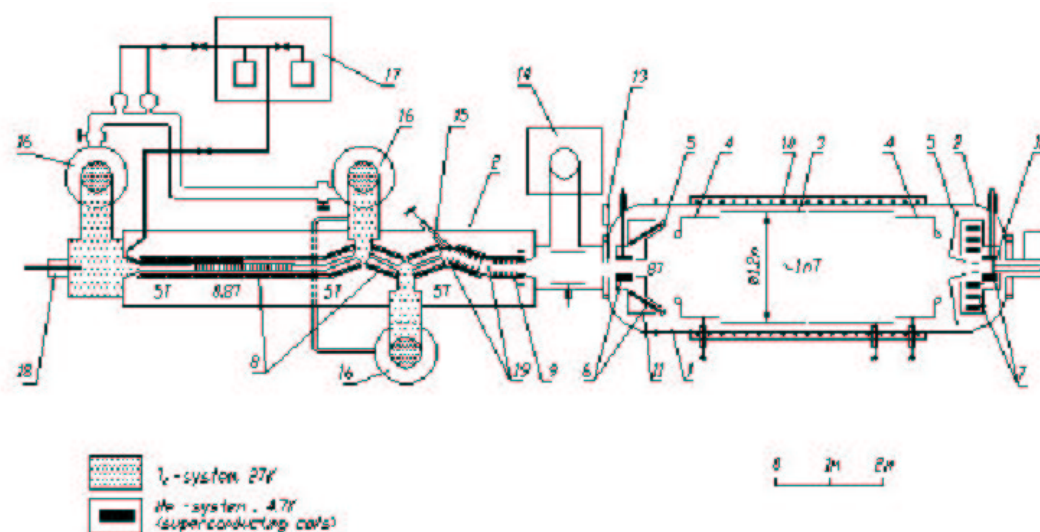

Fig. 1 The experimental setup at Troitsk showing a schematic of the magnetic solenoidal transport system and the electrostatic retarding field electrodes. See ref.[6] for details.

2 The Electron Neutrino Mass

The most well known, and until now the most sensitive, method of determining the mass of the electron antineutrino is by measuring the beta spectrum from tritium. Tritium has a low Q value of about 18.6 keV and is a superallowed beta decay. The lower the Q value the larger the fraction of betas in the kinematically interesting region of $Q - m \leq E \leq Q$. The half life is about 12.3 years which has a bearing on the thickness of the open beta source. The low Z value of the decaying nucleus implies that Coulomb distortions on the beta final state are small and the final He-T states, or their equivalents when tritium is part of a larger molecule, are calculable.

The first serious limit of $m = 55 \text{ eV}/c^2$ was put by Bergkvist⁴ using a magnetic spectrometer. Around 1980 a Russian group⁵ claimed to have found a non zero value of about $30 \text{ eV}/c^2$. This set off a flurry of experiments to confirm the above finding. However all these experiments failed to find the non zero mass. They ended instead in setting upper limits of about $10 \text{ eV}/c^2$ on the mass and ruled out the mass found by Lubimov et al⁵. In view of the fundamental importance of the neutrino mass a new generation of experiments was launched to look for a smaller mass, if any. These experiments used a combination of a slowly varying solenoidal magnetic field to transport the electrons with energy larger than a certain applied retarding electrostatic potential. The retarding poten-

tial (V_R) was ramped to count the integral spectrum beyond V_R . Very large efficiencies of 50% could be obtained while using a tritium source of large area and strength. Two groups at Troitsk⁶ and Mainz⁷ independently pioneered the use of such a spectrometer. As of 2002 both groups have an upper limit of about $2.4 \text{ eV}/c^2$. A combined experiment has been proposed⁸ with substantial improvements to the setup to search for a non-zero mass down to about $0.35 \text{ eV}/c^2$.

The Troitsk Experiment

The integral beta spectrometer (see Fig.1) has a strong inhomogeneous magnetic field to guide and collimate the electrons and a retarding electrostatic field. The latter is generated by a set of cylindrical electrodes to which are applied suitably graded voltages.

The spectrometer has an approximate step function energy response rising from 0 to 1 within an energy span of $\Delta E = E(H_{min}/H_{max})$ where H_{min} and H_{max} are the magnetic field strengths at the median plane of the spectrometer and the entrance, respectively. Differentiating the measured integral spectrum gives the familiar beta energy spectrum. The energy resolution in most measurements was between 3.5 to 4.7 eV.

The tritium source consists of the gas fed at the centre of a 3 meter long tube either end of which is pumped by mercury diffusion pumps. The tritium is

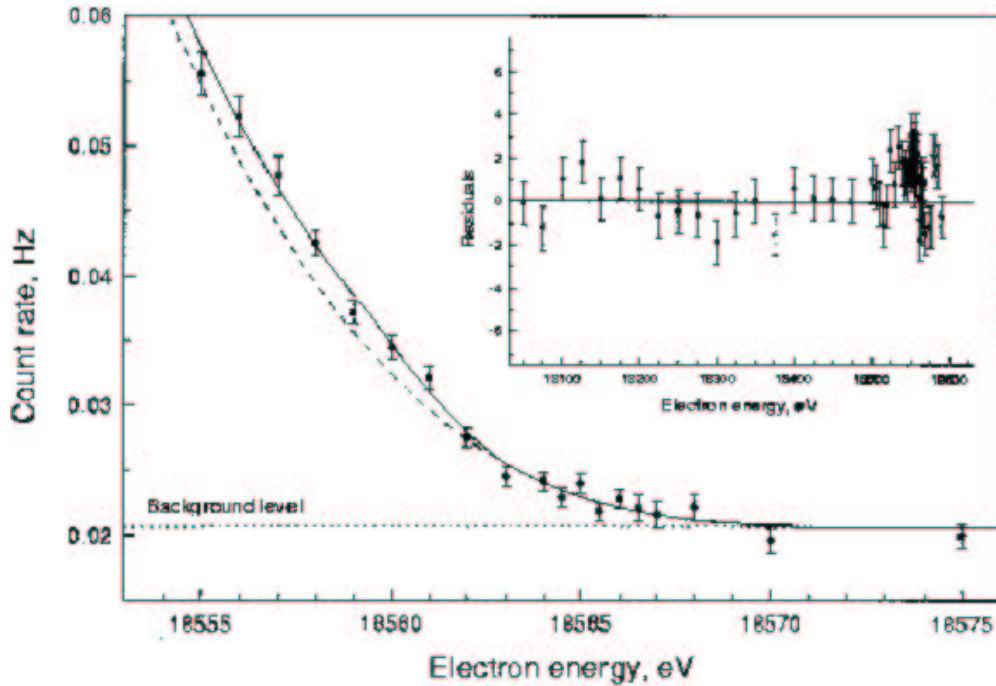

Fig. 2 The measured integral spectrum versus retarding voltage near the end point of tritium from the Troitsk experiment⁶. The dashed line shows the spectrum after removal of a line with intensity about 10^{-10} of the total decay rate. Also shown in the box are the residuals to the fitted spectrum as a function of electron energy.

further compressed by mercury booster pumps, purified by passing it over hot getters and injected back into the tube. In the closed loop the source temperature is maintained at about 27° K so that most gaseous impurities are frozen out except helium, the hydrogen isotopes and neon. The differential pumping ensures high vacuum in the main spectrometer chamber. The decay electrons from the tritium are transported using guiding magnetic fields to the entrance of the main spectrometer. The response of the finite thickness of tritium gas in the path has to be taken into account when reconstructing the original spectrum. The integral electron spectrum close to the end point is measured by ramping the retarding electrostatic field and counting the electrons with a cooled lithium drifted silicon detector. The data had to be corrected for various effects such as a) electron trapping in the magnetic field and subsequent energy loss, b) different final molecular states in He-T⁺, c) variation in tritium source strength, d) dead time correction and e) pileup of signals. An example of such a spectrum is shown in Fig.2.

A careful analysis of the data revealed a line about 5 to 12 eV below the end point with an intensity of $2 - 7 \times 10^{-11}$ of the total decays. The origin of this

line has not yet been found though many investigations were done to look for a possible systematic error. Accumulated data upto about 2000 show the so called "Troitsk anomaly". The runs beyond 2000 do not seem to have this feature. If such an anomaly is subtracted out of the data the extracted m_ν^2 is $-2.2 \pm 2.3 \pm 2.0$ eV/c² at 95 % C.L. and an upper limit of 2.2 eV/c² can be placed on the mass of the electron antineutrino at 95% confidence level(C.L.)⁹.

The Mainz Experiment

The spectrometer is essentially similar to the Troitsk set up. The major difference is that the tritium source consists of T₂ gas adsorbed on a highly oriented pyrolytic graphite backing which is maintained at cryogenic temperatures($\sim 1.9^\circ$ K). The earlier runs used a slightly higher temperature where a "roughening" transition was identified. This led to a small excess of lower energy electrons arising from the increased energy loss of the highest energy (near the endpoint energy) electrons. This is probably the reason for the large negative m_ν^2 from the early (pre-1994) runs. Various improvements and supplementary measurements such as a) decrease of the background (at energies higher than the endpoint) by ~ 2 effected

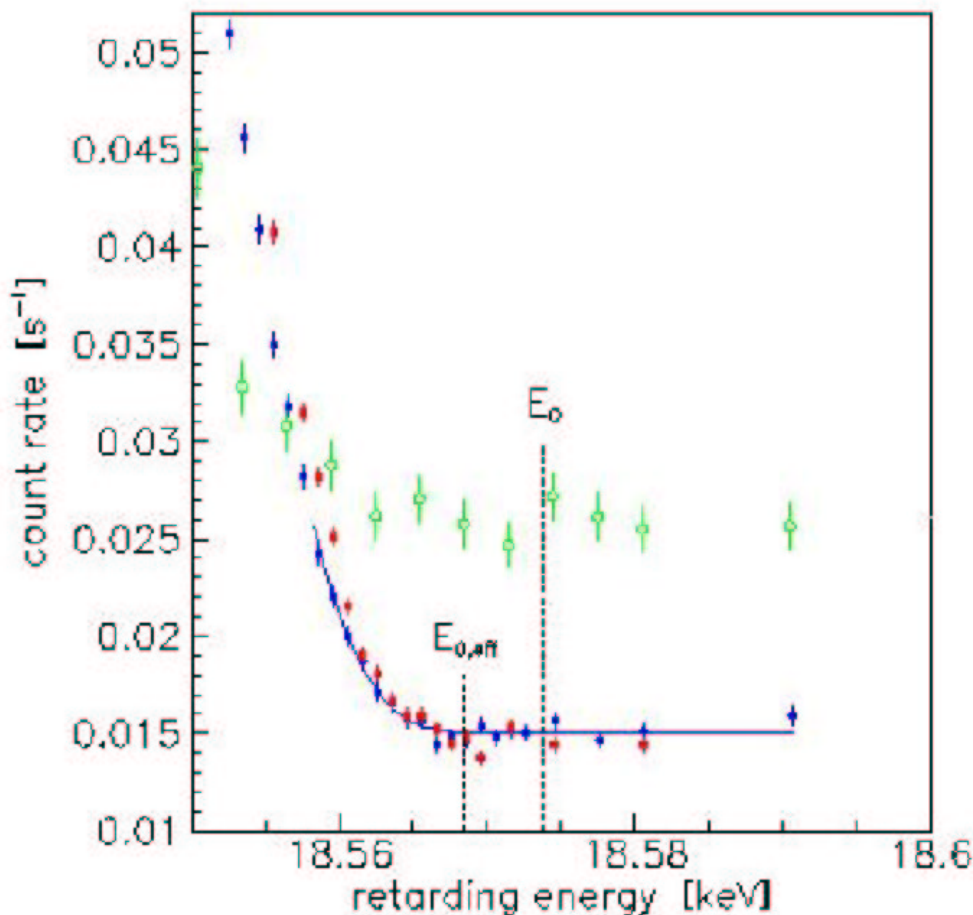

Fig. 3 The measured beta count rate versus retarding voltage from tritium near the end point from the Mainz experiment. The open circles show the 1994 data and filled circles data taken after improvements in the setup.

by installing a cryotrap in the bending magnets immediately after the source in spite of an increase in source strength by ~ 7 , b) better alignment of various components of the spectrometer leading to an improvement in energy resolution from 6.6 to 4.4 eV, c) better temperature control $\pm 0.03^\circ$ K, d) measurement of inelastic scattering of electrons in thin tritium film and e) measurement of self charging of tritium film due to beta emission were done over the years to identify and reduce systematic errors. Fig.3 shows a comparison of some of the early data alongwith the more recent data. Using only the data from 1998 onwards the extracted value for m_ν^2 is $-1.2 \pm 2.2 \pm 2.1$ eV/c² at 95 % C.L. implying an upper limit of 2.2 eV/c² on the mass of the electron antineutrino at 95% C.L.¹⁰.

Limits from Supernova Neutrinos

This uses the time of flight technique to measure

the few neutrinos detected from a nearby supernova explosion. Here use is made of the large distance between the supernova and a terrestrial neutrino detector. The arrival time difference between a zero and finite mass neutrino is given by

$$\Delta t_\nu = 5.2 D_{SN} (m_\nu/E_\nu)^2 \quad \dots (2)$$

where Δt_ν is in milliseconds, D_{SN} is the distance of the supernova from the Earth in units of 10 kiloparsec, m_ν is the neutrino mass in eV/c² and E_ν is the energy of the neutrino in units of 10 MeV/c². The time profile of the neutrino burst can be calculated and compared with the experimentally measured time sequence. This has been used to put¹¹ a conservative upper limit of 23 eV/c². From the same data a more stringent, but model dependent, limit of 13 eV/c² can be derived¹².

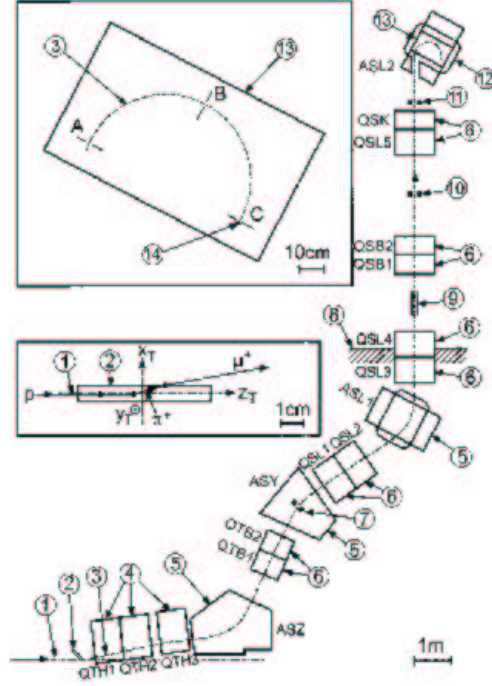

Fig. 4 Schematic diagram of PSI experiment.

3 The Muon Neutrino Mass

The mass of the muon neutrino can be measured by a method slightly different from that used for the electron antineutrino. The two body decay of the charged pion is used for this purpose. Pions are produced copiously when a high current proton beam is incident on a thick target of a light element. In the earlier experiments they were transported by electromagnetic elements to a secondary target area. This was done to remove interference from particles other than the charged pion. The pure beam of pions is then stopped in a target and the subsequent charged muon resulting from pion decay is momentum analysed. The mass of the undetected muon neutrino can then be calculated from the relation

$$m_{\nu_\mu}^2 = m_\pi^2 + m_\mu^2 - 2m_\pi \sqrt{(m_\mu^2 + p_\pi^2)} \quad \dots(3)$$

Such an experiment was first done at the PSI, Switzerland and yielded an upper limit of about 0.27 MeV/c². A later experiment¹³ at PSI used the same target to both produce and stop pions (see Fig.4). This led to an increase in the stopped pion intensity by about 10⁴. Another improvement over the earlier measurements is the use of horizontal and vertical position sensitive silicon detectors to detect the muon after a 180° momentum analysis system. The muon mo-

mentum is measured to a precision of 3.7 ppm leading to an upper limit on the square of the muon neutrino mass of 0.17 MeV/c² at 90% confidence level. This upper limit is mainly due to the error in the pion rest mass (2.5 ppm) and can be reduced further if the latter is measured more precisely.

4 The Tau Neutrino Mass

The best limit on the mass of the tau neutrino is from an analysis of Barate et al¹⁴ using the decay of the Z₀ followed by the decay of one of the tau leptons to the 3- and 5- particle decay channels. If the tau neutrino has a non-zero mass the maximum energy of the hadronic state in the tau lepton rest frame can be $m_\tau - m_{\nu_\tau}$. The energy of the hadron in the tau-lepton rest frame is given by

$$E_{h^*} = (m_\tau^2 + m_h^2 - m_{\nu_\tau}^2)/2m_\tau \quad \dots(4)$$

This has a maximum when $m_{h^*} = m_\tau$. In the laboratory frame this maximum energy will be

$$E_{beam}(1 - m_{\nu_\tau}/m_\tau). \quad \dots(5)$$

The ALEPH collaboration at LEP analysed a sample of 2939 events of the former and 52 events of the latter type and plotted the ratio of the hadronic energy to beam energy versus the invariant hadron mass m_{h^*} , as

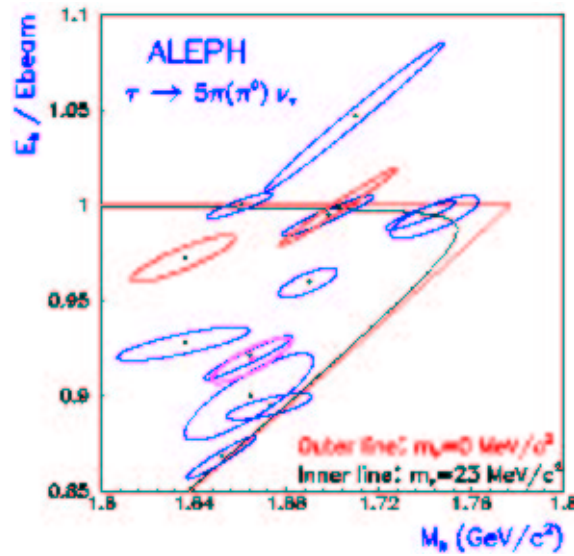

Fig. 5 Plot of E_e/E_{beam} vs m_{ν_τ} for Type 2 events. Also shown is the limit of the distribution for $m_\nu = 0$ and $19 \text{ MeV}/c^2$.

shown in Fig.5. An upper limit of $18.2 \text{ MeV}/c^2$ has been placed on the mass of the tau neutrino.

Concluding Remarks

The most stringent upper limit on the mass of the neutrino is for electron neutrinos of $\sim 2.2 \text{ eV}/c^2$. The corresponding upper limits for the muon and tau neutrinos

are $0.27 \text{ MeV}/c^2$ and $18.2 \text{ MeV}/c^2$, respectively. If the electron neutrino mass is greater than $\sim 0.4 \text{ eV}/c^2$ it will be measured by the next generation tritium experiment, KATRIN. If the neutrino is a Dirac particle and lighter than $0.4 \text{ eV}/c^2$ what can be done? Since the present and planned experiments will not be sensitive to a smaller mass, a radically different and new approach is called for.

References

- 1 Q R Ahmad *et al Phys Rev Lett* **89** (2002) 011301
- 2 K Eguchi *et al Phys Rev Lett* **90** (2002) 021802
- 3 V M Datar *et al Nature* **318** (1985) 547; For a complete listing see Particle Data Group *Phys Rev D* **66** (2002) 010001 and references therein
- 4 K E Bergkvist *Nucl Phys B* **39** (1970) 317
- 5 V A Lubimov *et al Phys Lett B* **94** (1980) 266
- 6 V A Lobashev and P E Spivak preprint INR P-0291 Moscow (1983); *ibid Nucl Instr Meth A* **240** (1985) 305; V M Lobashev *Progress in Particle and Nuclear Physics* **40** (1998) 337
- 7 H Backe *et al Nuclear Beta Decays and Neutrino Proc Of the Int Symp Osaka Japan* (1986); *ibid Phys Scr T* **22** (1988) 98; A Picard *et al Nucl Instr Meth B* **63** (1992) 345; H Barth *et al Progress in Particle and Nuclear Physics* **40** (1998) 353
- 8 KATRIN proposal see review talk of C Weinheimer in Neutrino 2002 (Munich)
- 9 C Weinheimer invited talk at Neutrino 2002 XXth International Conference on Neutrino Physics and Astrophysics Munich May 25–30 (2002); See also for earlier published results VM Lobashev *et al Phys Lett B* **460** (1999) 227 and references therein
- 10 C Weinheimer invited talk at Neutrino 2002 XXth International Conference on Neutrino Physics and Astrophysics Munich May 25–30(2002); See also for earlier published results Ch Weinheimer *et al, Phys Lett B* **460** (1999) 219 and references therein
- 11 N D Hari Dass, D Indumathi, A S Joshipura and M V N Murthy *Curr Sci* **56** (1987) 575
- 12 T Totani, K Sato, H E Dalhed and JR Wilson *Ap J* **496** (1998) 216
- 13 K Assamagan *et al Phys Rev D* **53** (1996) 6065
- 14 R Barate *et al Eur Phys J C* **2** (1998) 395